



## TECHNICAL BULLETIN

# OFF ROAD GENERAL REQUIREMENTS - 2010 SIDE INTRUSION REQUIREMENTS

### REFERENCE:

CAMS Online Manual of Motor Sport, OFF ROAD, General Requirements (GR) for Off Road Vehicles.  
[http://www.camsmanual.com.au/05\\_offroad.asp](http://www.camsmanual.com.au/05_offroad.asp)

### RATIONALE:

To provide additional side impact protection to buggy occupants over that provided by some existing designs.

### ACTION:

Amend GR 9 CHASSIS/FRAME by the addition of Article 4.2 as follows:

#### 4.2 Side protection

##### (a) General

To ensure that buggy occupants are provided with additional protection in a side impact situation over that provided by some existing designs, the following requirements shall apply from 1 January 2010.

Each frame shall have an upper side bar (formerly referred to as the 'hip rail') on both sides of the frame, of dimensions meeting the minimum tube sizes outlined in Article 5, Materials, positioned not less than 450mm from the lowest part of the bottom chassis rail to top most part of the upper side bar, measured vertically at the midpoint between the main hoop and front leg (refer Diagram 4.2a).

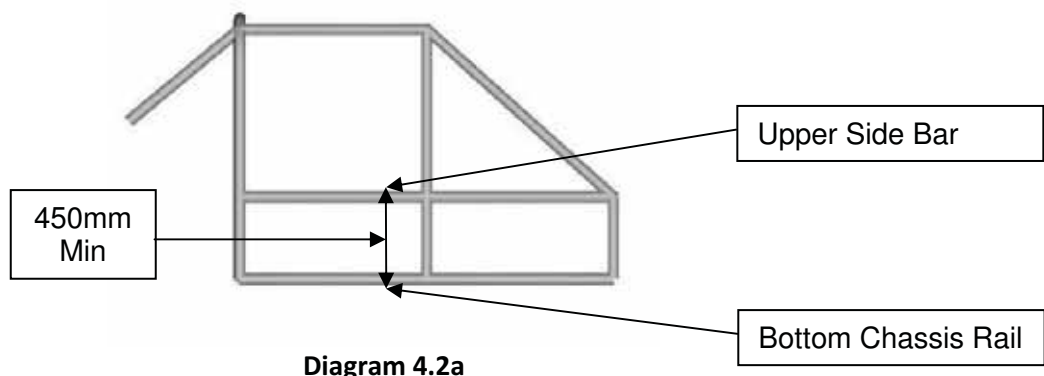

**(b) Side Protection Additions**

**Where a frame does not comply with the requirement outlined in (a) in its present configuration, additional side protection members shall be added, as follows:**

**(i) Method 1**

**Design incorporating a single continuous straight tube which is attached to the main hoop and front leg.**

**This option applies only to a vehicle where the bar can be installed without a bend whilst still providing adequate clearance for the crew.**

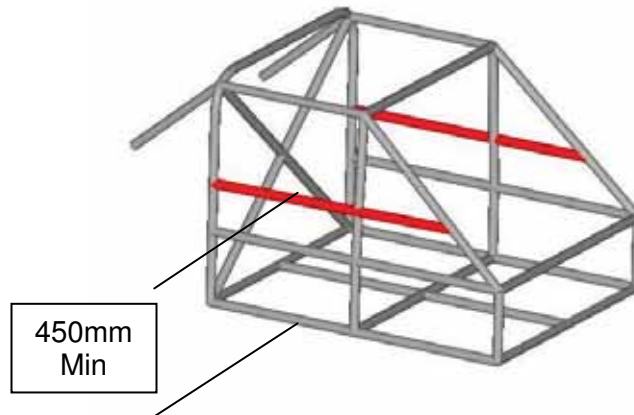

**Diagram 4.2b**

**(ii) Method 2**

**Design incorporating a single tube attached to the main hoop and front leg, with at least one additional supporting member.**

**This option applies to a vehicle where additional clearance is required for the crew, either when seated in the vehicle (space for the shoulder or arm to fit within) or to provide adequate space for entry and exit.**

**The location of the supporting member is at the discretion of the competitor. The purpose of this bar is to reduce the likelihood of the horizontal bar being bent vertically in an impact.**

**A structure built to this design shall not take the place of a nerf bar.**

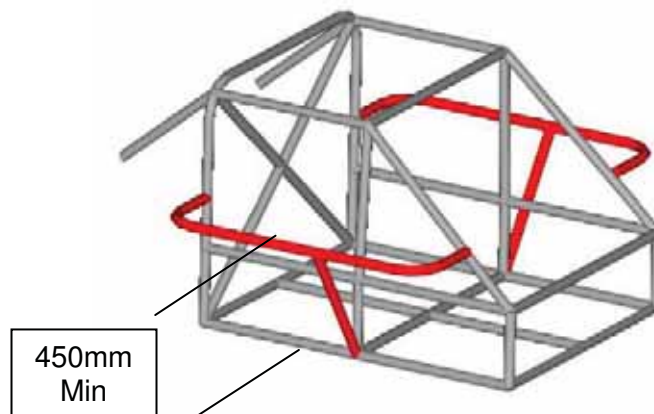

**Diagram 4.2c**

**(iii) Method 3**

**This option is suggested as a comprehensive solution which will provide a higher level of protection than the other options.**

The design shall consist of an upper and lower bar, including a reinforcing cross design utilising either two uninterrupted tubes joined by a gusset at the cross (preferred), or a 'conventional' cross design where one of the tubes is cut and welded to the uninterrupted tube (in which case gusseting of this join is recommended).  
The side protection structure shall be no less than 800mm in length at both the upper side rail and bottom chassis rail unless the front leg to main hoop dimension where the structure is attached is less, in which case that dimension shall be the minimum.

Minimum tubing dimensions: 38mm x 2.5mm

Refer to article 5, Materials, for material specifications.

The lower side protection bar shall be attached to the bottom chassis rail.

A structure to this design may take the place of a nerf bar, if the structure also complies with the requirements for a nerf bar.

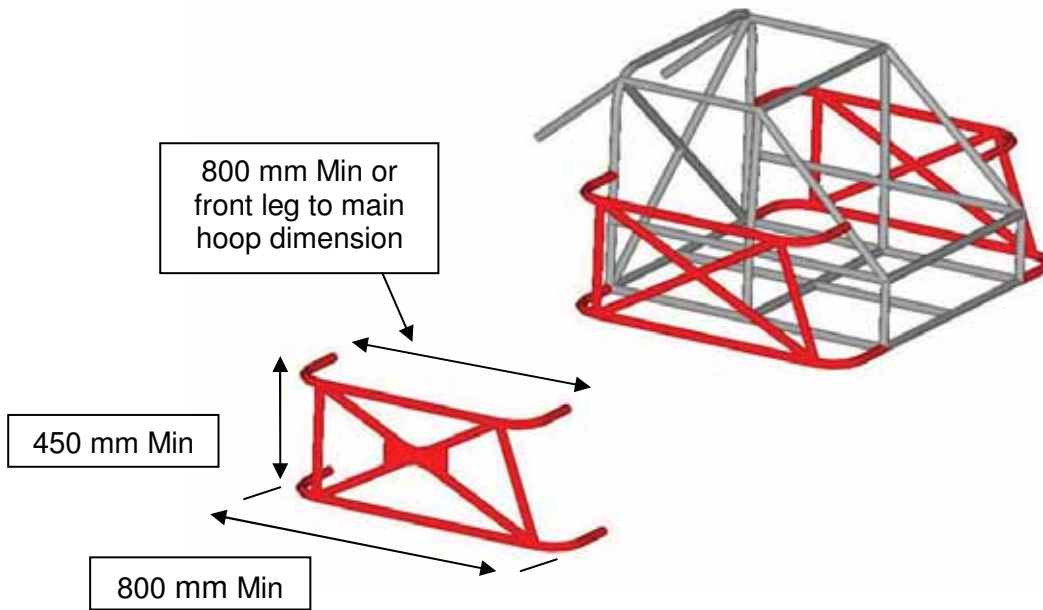
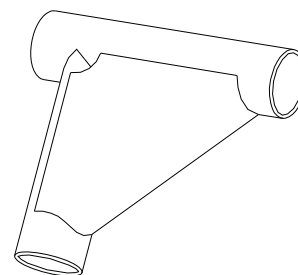

**Diagram 4.2d**

**Gusset:**

Reinforcement for a bend or junction made from bent sheet metal with a U shape (drawing 253-34) the thickness of which must not be less than 1.0 mm.

The ends of this reinforcement must be situated at a distance from the top of the angle of between 2 to 4 times the diameter of the biggest of the tubes joined.



**Drawing 253-34**

**Diagram 4.2e (Detail of Gusset to be utilised)**

**(c) Attachment**

Any of the following methods of attachment may be utilised:

1. Welding

- 2. Sleeved joiner welded to the frame, additional framework attached on the frame by at least one grade 8.8, 10mm bolt.  
Refer Diagram 253-34 or 253-35 in CAMS Manual Schedule J Safety Cage Structures
- 3. Bolted flanges. Each flange with a minimum area of 100cm<sup>2</sup> shall be at least 3mm thick (minimum 6mm total when two flanges are butted together). The additional framework shall be attached by at least two grade 8.8, 8mm bolts at each flange attachment.

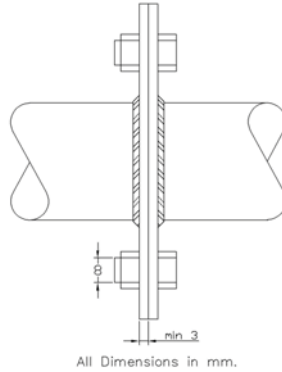

**Diagram 4.2f**

**(d) Additional guidance on fitment**

**While minimum standards have been set, Competitors should consider the rationale for this requirement and design the additional side protection structures to provide as high a level of protection practicable.**

**450mm has been set as a minimum dimension between the bottom chassis rail and upper side bar. Due to the varying configuration of each car, in particular the height the seat is mounted, it would be appropriate in some circumstances for the upper side bar to be fitted higher. Competitors should consider their own vehicle’s configuration and fit the bar (including any additional reinforcement) in such a way so as to afford the best compromise between protection and crew exit space.**

**In accordance with Article 1, adequate space to exit the vehicle must be maintained in any chosen method. This may be achieved by moving the side protection structure further outboard from the existing frame structure.**

**Key to diagrams**

**Red – mandatory tube member from 1<sup>st</sup> January 2010**

**Blue – recommended tube to be considered for the provision of additional strength**

**Grey – minimum requirements of GR9 prior to 1<sup>st</sup> January 2010**

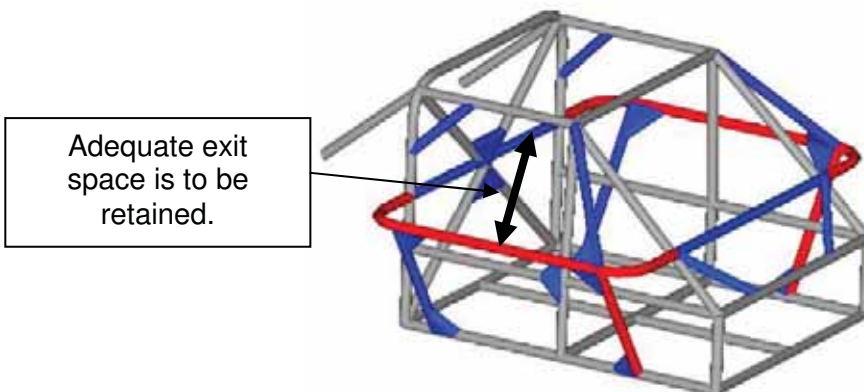

**Diagram 4.2g**

**(e) Recommended Reinforcement for Consideration**

**Extra bars may be added for increased strength.**

**Additional gusseting or support tubing is recommended where the upper side bar does not align with existing tubing on the same plane.**

**Gussets may be added to all welded tube joins as depicted in Diagram 4.2i.**

**The following diagrams depict some potential additions for the consideration of competitors.**

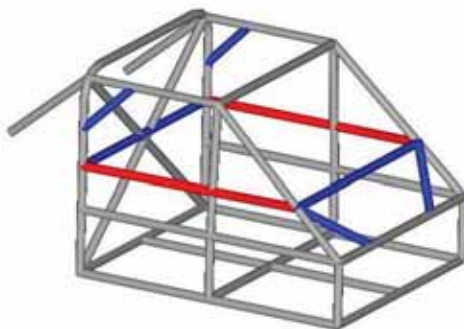

**Diagram 4.2h**

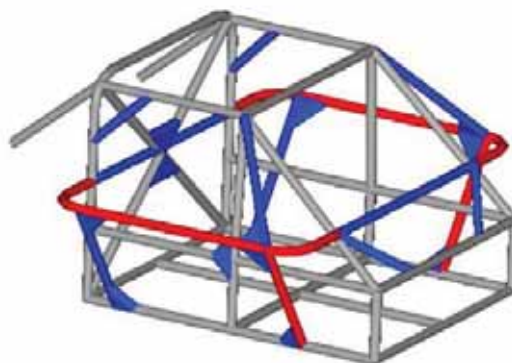

**Diagram 4.2i**

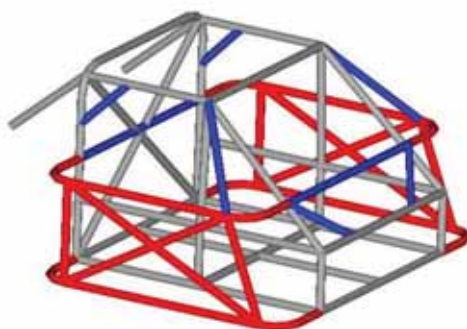

**Diagram 4.2j**

**ENDS**